



Human – Computer Interaction

interaction design

Lecture No. 7

Dionysios Politis
Dept. of Informatics



European Union
European Social Fund



MINISTRY OF EDUCATION & RELIGIOUS AFFAIRS
MANAGING AUTHORITY

Co-financed by Greece and the European Union



License

- This educational material is subject to Creative Commons licensing.
- For educational material such as images, that subjects to another form of licensing, the license is explicitly referred.



Funding

- This educational material has been developed as part of the educational work of the academic teacher.
- The project “Open Academic Courses at the Aristotle University of Thessaloniki” has only funded the reconfiguration and reshaping of the educational material.
- The project is implemented under the Operational Program “Education and Lifelong Learning” and is co-funded by the European Union (European Social Fund) and National resources.



Mobile Devices & HCI

**their contribution to
interaction design**



Apple: the progenitor *(1/3)*

- 2001
 - Circulation of the iPod, a storage device and music player (later acquired playability for photos and video).
 - Although it was not the first device of its kind, the good design, ease of use and the successful promotion of the company in the US and Western Europe made it the most popular product of its kind, on the cusp of winning over 70% of the market.
 - iTunes is the software which has been promoted by Apple to connect the iPod with computers so that they can be synchronized with iPod, importing / exporting music, pictures, videos, calendars, directories, etc.
- Apple is considered a pioneer company in the field of design, having as a basic principle minimalism, i.e. “Less is More”.
- iPod and iTunes changed the way the world thinks of music and its use, and organized media distribution with PCs, the extraordinary iMac and mobile phones: as a result, iPhone makes all companies strive to duplicate its characteristics.

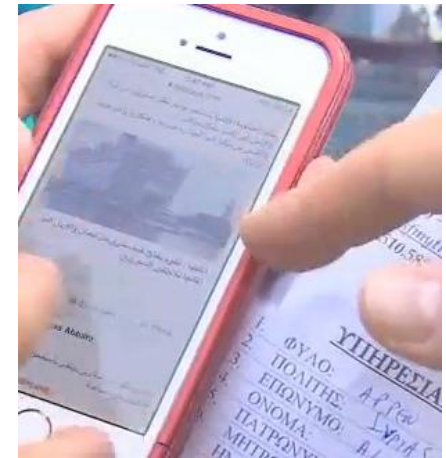

Source: CNN, YouTube



Apple: the progenitor (2/3)

- Apple did not create the the digitized music frenzy (MP3s et al.).
- Apple has not invented mobile music instrumentation or resources (MP3 player).
- Apple has used these (and other...) existing technologies / products, combined with an innovative service (the online iTunes music store) and offered a new, pioneering digital entertainment experience to the end user / customer.
- Evolution of the iPad
 - The company until 2007 was called Apple Computing.
 - Today the second word of the title does not exist, although it still produces computers. But it has become the first worldwide producer of electronic handheld devices, outpacing the sales of Nokia and Sony.
 - Apple has not yet brought a new product.
 - But Apple brought a new idea about how technology can be used.
 - And not even a new idea. Flat touch computers existed for years.
 - **Apple has just proposed a new way to handle them!**



Apple: the progenitor *(3/3)*

- In a nutshell ...



iPod Shuffle



iPod Nano



iPod Classic



Apple TV



iPod Touch



iPhone



iPad



MacBook



MacBook Pro



MacBook Air



Mac Mini



iMac



Wearable technology

- It is clothing, accessories and body parts, which embrace computer equipment and advanced electronic technologies, that become portable enough to be worn or carried on one's body.
- Their design often incorporates practical functions and features.
- Somehow wearable technology is also related with the recent development of laptops.
- Portability does not only push for smaller or lighter than usual; It engages habitually everyday life technology.
- Through the development of wearable computing technology, the pioneers tried to strengthen or extend the functionality of garments, by creating wearable accessories that are able to provide users with transportable multimedia recordings of complex activities via short-range radio emissions.

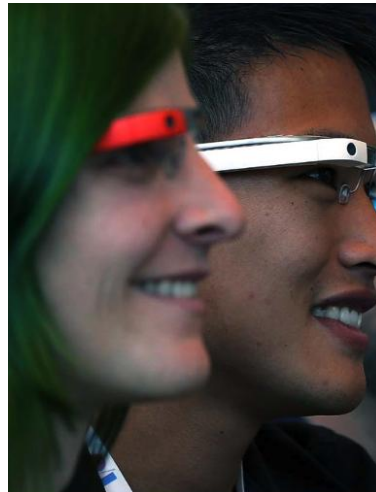

Sources: Getty, Google & MEDEL



M-Learning (1/2)

- The term Mobile Learning or m-Learning refers to the process of learning in which the learner is not at a certain point, or more generally when the learner uses mobile devices for education.
- While m-Learning was previously limited to laptops, today it mainly refers to **smartphones, tablets, or mobile gaming and entertainment consoles.**
- The advantages of Mobile Learning lies mainly in the use of educational programs that do not depend on time and space,
 - i.e. I am learning what I want, where I want and whenever I want.

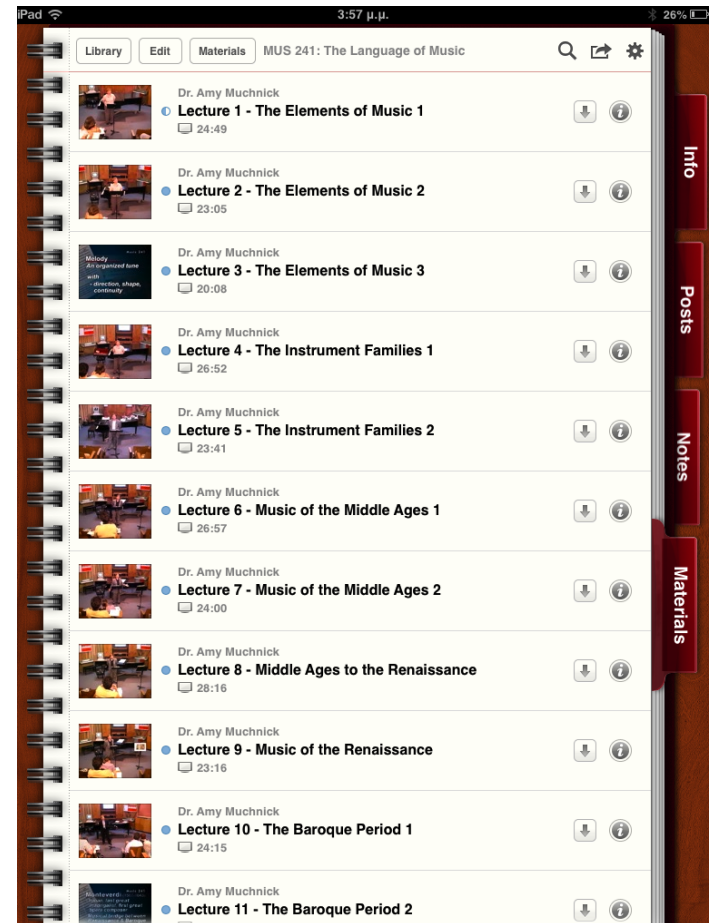

M-Learning (2/2)

- m-Learning does not bring a revolution by simply transferring the content of web-based education (PowerPoint presentations, pdf documents or Flash animations, etc.) to the mobile world.
- Contents of mobile learning should:
 - be simple (“Less is more”),
 - easily accessible ,
 - with “attractive” design.
- Although mobile devices have many advantages over personal computers in terms penetration, availability and ubiquitousness they have very small displays and managing content on screen needs new orientation, i.e. new Design-oriented Human-Computer Interaction.
- Mobile devices are especially capable in recording, distributing or sharing Rich Content, i.e. the combined use of on-the-spot media, such as movies, animations, photos, recordings ... The high quality cameras and sound recording devices they possess promote new media formats and features in Mobile Learning.
- Other notable features like GPS trackers, gyroscopes and accelerometers provide a new context framework for conducting e-Learning activities like e-Tests with unparalleled levels of Interaction.
- Overall, e-Learning is radically reshaped offering “attractive”, easily accessed rich content to global audiences.

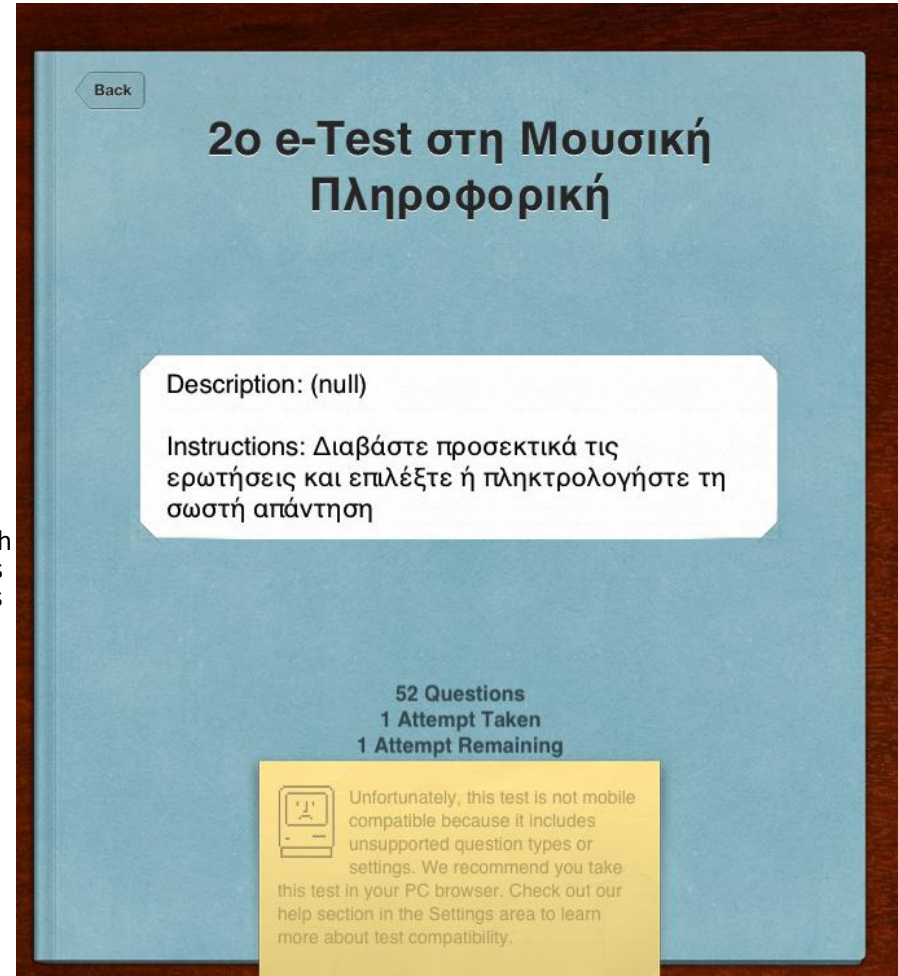

Advantages of using mobile devices

- The main advantages of using mobile devices in learning are:
 - Ease of use
 - Availability and flexibility of use even outside the classroom
 - Wide range of uses
 - Unprecedented penetration which promotes the Knowledge Society to all widths and lengths of our planet's surface
 - Mobilization and sharp interest due to the combination of new technologies with social media
 - Maximum portability
 - Better access to information sources, fostering divergent learning styles
 - Fun to work with, through the gamification of learning
 - Self-paced and independent study is possible



Statistical data

- In many surveys focusing on media use and attitudes within the secondary education, the incorporation of iPad learning applications provides strong motivation for children aged 11-18 years.
- Gamification is another factor that increases the engagement factor in education. Groundbreaking interactive science applications give other dimensions for the future of education.
- Although classic fields of education like Maths do not benefit that much (thus far) from m-Learning, students' parents stressed out that the use of portable technologies encourages and exhorts learners towards innovative approaches as far as the business and social orientation of human capital is concerned.
- Finally, teachers point out that the cases of misuse for these devices have a very small impact compared to the potential benefits they offer.



Brain Computer Interfaces (BCIs)

- It is the Brain-Computer Interface, sometimes called a direct neural interface or a brain-machine interface, that reshapes HCI.
- Essentially it is a direct path for communication between the brain and an external device.
- The BCI is also a communication system in which messages or commands send by an individual to the outside world, do not have to go necessarily through the normal pathways of the brain.
- It involves interface – cooperation by which the brain accepts and controls an augmentation system as a “natural” part of the body.
- For computer scientists it is a communication system that translates brain activity into commands that can be processed by a computer or other similar devices.



The road towards BCIs (1/3)

- Many people suffer from neural impairments or some other kind of disability. There are two ways to overcome the problem :
 - By “repairing” damaged neuron synapses
 - by means of prosthetics that have computer intelligence
- It is useful for People With Disabilities:
 - with limited muscle control
 - with spinal cord injuries
 - with memory loss
 - blind
 - Impaired in hearing
 - etc ...

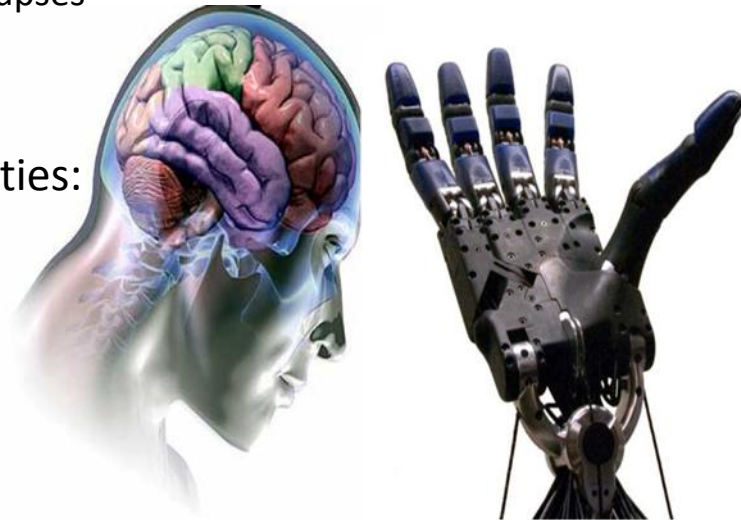

Source: pulse.ng



The road towards BCIs (2/3)

- When computer technology is involved with augmentation, the issues of Interface Design, Interaction Design and Usability come to the frontbench:

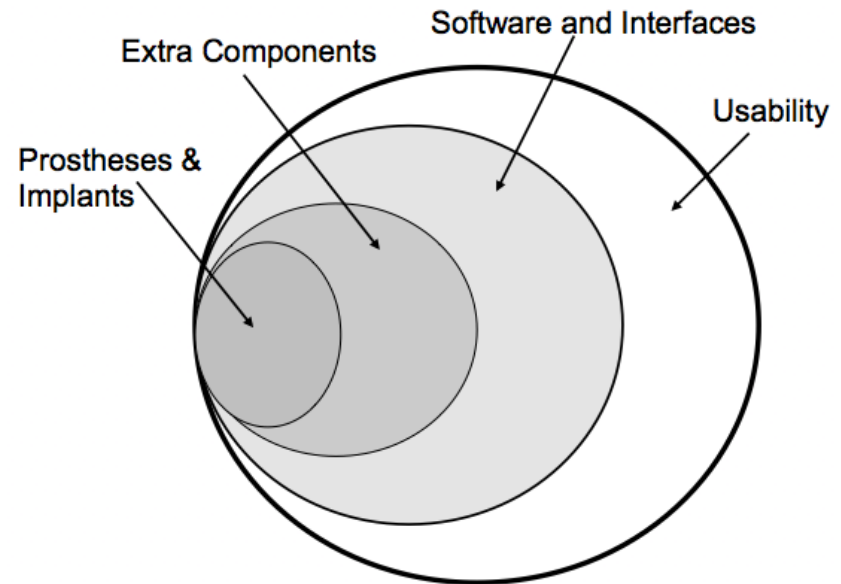

The road towards BCIs (3/3)

- Computer technology becomes then an enabler with an unspecified (yet) number of future applications, especially within the Web 3.x context.

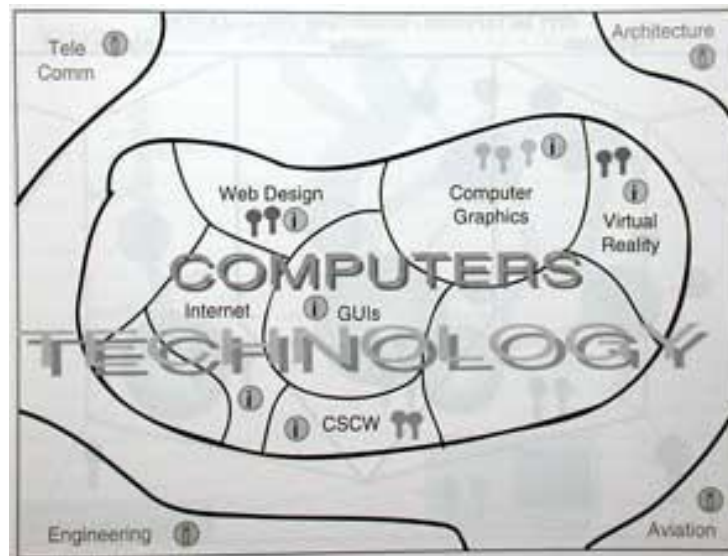

Musical Interfaces

& Usability



Musical Interfaces (1/3)

- MIDI Template:
 - It is the first large-scale interface in the world of Music
 - It allows musical instruments to be connected together
 - Disadvantage:
 - The lack of standardization for the new modules of synthesizer produced music

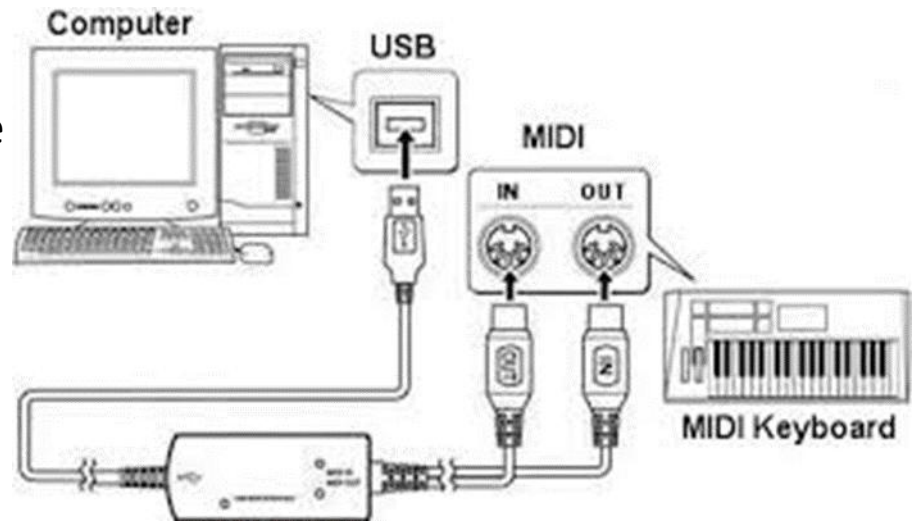

Source: musicrepo.com



Musical Interfaces (2/3)

- Digital Music Management: The instruments, the software ...

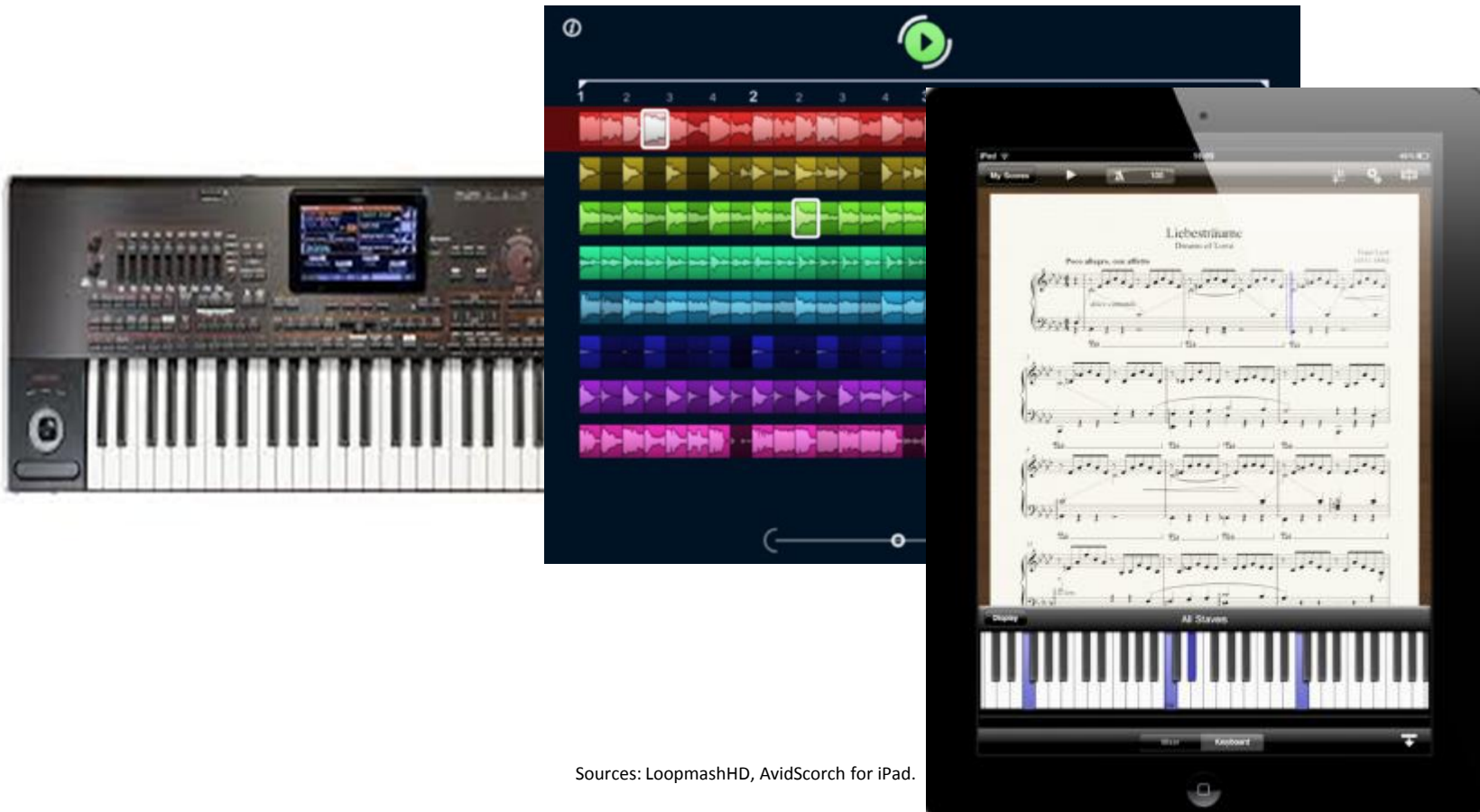

Sources: LoopmashHD, AvidScorch for iPad.



Musical Interfaces (3/3)

- ... the Web.



Source: NanoStudio for iPhone

Conclusions

- Either for the disabled or for normal users, the potential of mobile devices is unparalleled for the creation, distribution and learning of via Rich Media.
- Portable devices thus acquire added value through increased interaction either for multimedia purposes (such as Music recording, editing or commercial promotion) or for learning.
- Computer Music inherently convolves with BCIs and promotes rich-interaction practices and techniques.



End of the 7th Lecture

Sources :

- D. Akoumianakis, COMPUTER-USER INTERFACE – a modern approach
Kleidarithmos Publications , Athens 2006 (in Greek)
- B. Schneiderman & C. Plaisant, Designing the User Interface: Strategies for Effective Human-Computer Interaction
5th Edition, Pearson, 2009
- J. Preece, Y. Rogers, H. Sharp, INTERACTION DESIGN – beyond Human-Computer Interaction
4th Edition, John Wiley & Sons, 2015



Reference note

Copyright Aristotle University of Thessaloniki[©], Human Computer Interaction – Interaction Design – Lecture 7: “Mobile Devices & HCI - their Contribution to Interaction Design”.

Version: 1.0. Thessaloniki 2016.

Available from the web address: <http://delos.auth.gr>



Licensing note

This material is available under the terms of license Creative Commons Attribution [1] or later, International Edition. Excluding independent third-party projects e.g. photos, diagrams, etc., which are contained therein and are reported together with their terms of use in “Third Party Works Vitae”



The beneficiary may provide the licensee separate license for commercial usage of this work under request.

[1] <http://creativecommons.org/licenses/by/4.0/>

